

**Operating Instructions | Betriebsanleitung | Mode d'emploi |
Istruzioni per l'uso | Manual de instrucciones**

ACCULAB VICON

Electronic Precision Scales/Balances | Elektronische Präzisionswaagen | Balances électroniques d'analyse et de précision |
Bilancia elettronica di precisione | Balanzas electrónicas de precisión

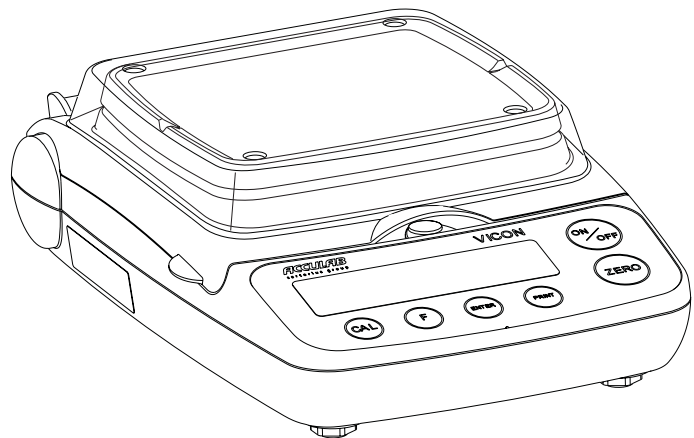
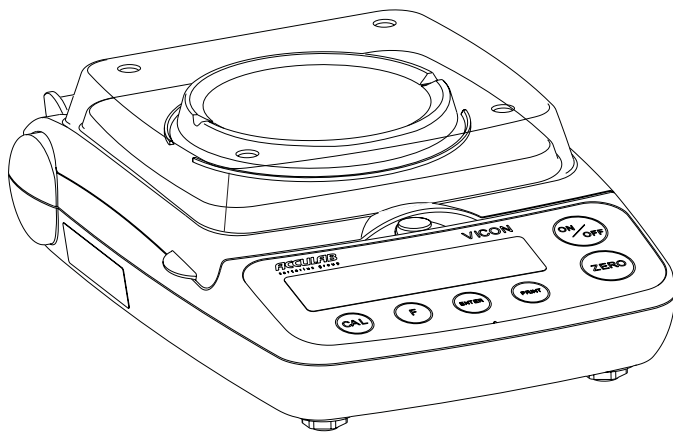

98648-012-72

Contents

English page 2

In cases involving questions of interpretation, the German-language version shall prevail.

Deutsch Seite 17

Im Auslegungsfall ist die deutsche Sprache maßgeblich.

Français page 32

En cas de questions concernant l'interprétation, la version en langue allemande fera autorité.

Italiano pagina 47

In caso di interpretazione, fa testo la versione in lingua tedesca.

Español página 62

En caso de interpretación, la versión en lengua alemana será determinante.

2 Warnings and Safety Precautions

3 Getting Started

5 Operation

5 Basic Weighing Function

5 Description of the Keys

Application Programs

6 Toggling between Weight Units

7 Counting

8 Weighing in Percent

9 "Hold" Display

10 Totalizing

11 Specific Gravity

12 Calibration/Span Adjustment

13 Configuration (Setup Menu)

14 Error Codes

Overview

15 Specifications

16 Accessories (Options)

16 C E Marking

Warnings and Safety Precautions

Safety Information

- To prevent damage to the equipment, please read these operating instructions carefully before using your balance/scale.
 - ⚠ Do not use this equipment in hazardous areas.
 - ⚠ Make sure the voltage rating printed on the power supply is identical to your local line voltage.
 - ⚠ Use only commercially available 9V batteries. If desired, you can use a rechargeable battery (not included).
 - The balance is energized at all times unless you disconnect the AC adapter and, if connected, the battery.
 - Protect the AC adapter from contact with liquid
 - ⚠ Exposure to excessive electromagnetic interference can cause the readout value to change. Once the disturbance has ceased, the instrument can be used again in accordance with its intended purpose.
- ### Installation
- It is recommended to connect Acculab accessories and options, as these are optimally designed for use with your balance/scale.
 - Do not open the balance/scale housing as this may void the manufacturer's warranty.

Getting Started

Equipment Supplied

- Balance/scale with in-use cover
- Weighing pan
- Plug-in AC adapter

Additional equipment with models VIC-612, VIC-412, VIC-212, VIC-711, VIC-511:

- Calibration weight

Additional equipment with models VIC-303, VIC-123, VIC-4MG, VIC-2MG:

- Calibration weight
- Round glass draft shield
- Level indicator and adjustable feet

Storage

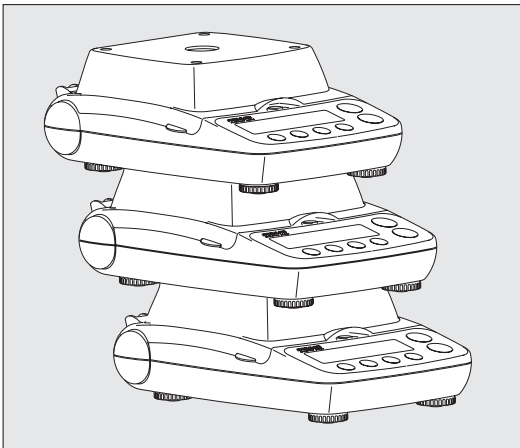

- Do not stack more than 3 balances on top of one another at a time.

Installation

Choose a location that is not subject to the following negative influences:

- Heat (heater or direct sunlight)
- Drafts from open windows and doors
- Extreme vibrations during weighing
- Excessive moisture

Setting Up the Balance/Scale

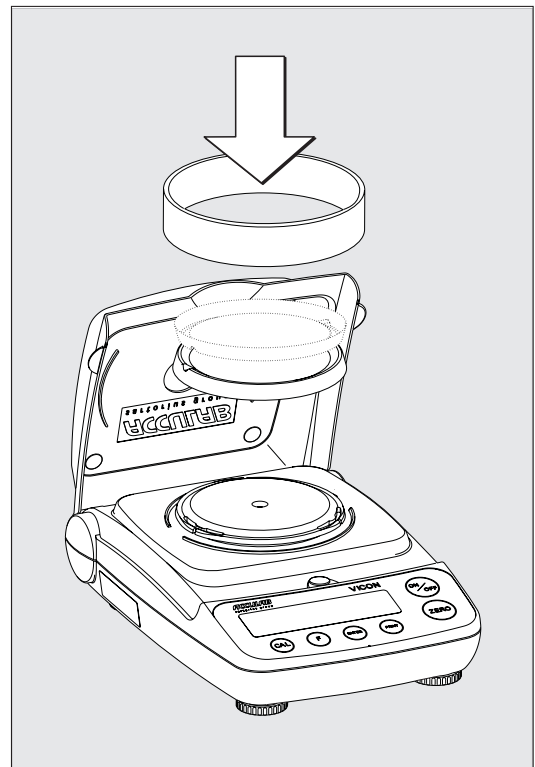

- Place the components on the balance/scale in the following order:
 - Reversible round weighing pan
 - Round glass draft shield on models VIC-303, VIC-123, VIC-4MG, VIC-2MG

Connecting the Balance/Scale to AC Power

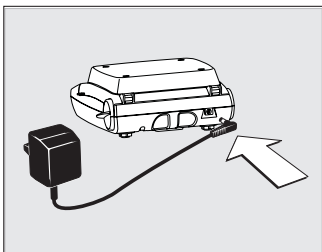

- It is recommended to use only the included AC adapter for optimal performance and safety.
- Insert plug into the jack (located on back of scale)
- Plug the AC adapter into an electrical outlet
- ⚠ LISTED power supply 11 V–21 V compliant with NEC Class 2 output.

Below-Balance/Scale Weighing

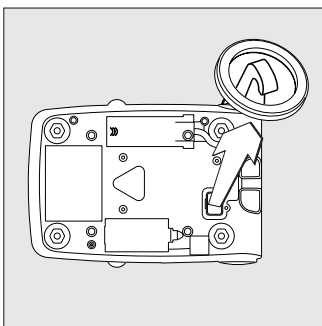

A port for a below-balance weighing hanger is located on the bottom of the balance/scale.

- Open the cover plate on the bottom of the balance/scale.
- Attach the sample (e.g., using a suspension wire) to the hanger.
- Install a shield for protection against drafts if necessary.

Installing the Battery

(not for models VIC-303, VIC-123, VIC-4MG, VIC-2MG)

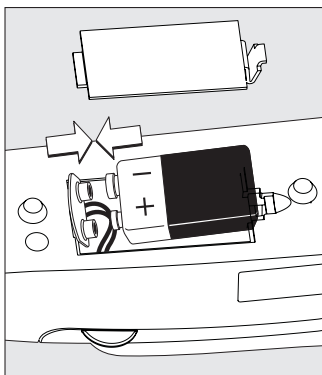

- Batteries are not included with the equipment supplied
- ⚠ Use only commercially available 9V batteries.
- ⚠ If you use a rechargeable battery, recharge it with an external battery charger.

- Lay the balance/scale on its side
- Open the battery compartment: remove the compartment cover
- Install the battery in the compartment

- Make sure the polarity is correct.

- ⚠ Close the battery compartment: slide the cover into position until it snaps into place

- ⚠ Do not throw away used batteries with normal household waste. Rechargeable batteries contain toxic materials and must be disposed of in accordance with local waste disposal regulations.

Leveling the Balance/Scale

(only for models VIC-303, VIC-123, VIC-4MG, VIC-2MG)

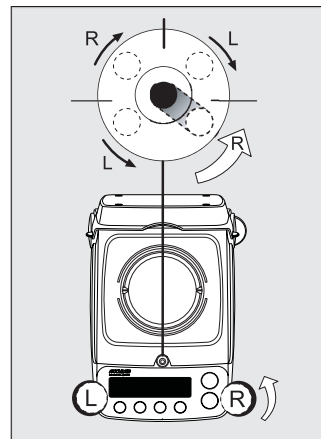

- Always level the balance/scale again any time after it has been moved to a different location. Example: moving bubble from R to L
- Turn the feet as shown in the diagram until the air bubble is centered within the circle of the level indicator.
- > In most cases this will require several adjustment steps.

Removing Weights for Calibration/Span Adjustment

(only for models VIC-612, VIC-212, VIC-711, VIC-511, VIC-303, VIC-123, VIC-4MG, VIC-2MG)

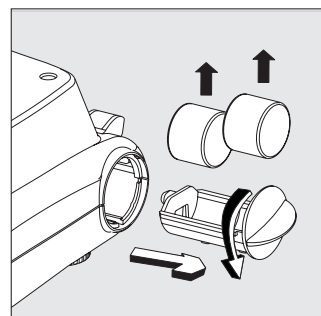

- Grasp the tab to turn and remove the weight compartment.
- Follow instructions on page 12 for calibration/span adjustment.

Operation

Basic Weighing Function

Features

- Zeroing the balance
You can zero the balance/scale within the entire weighing range, up to the maximum capacity.



Preparation

- Switch on the balance/scale: press the (ON/OFF) key
- If necessary, zero the balance/scale: press the (ZERO) key
- If necessary, change the configuration settings: see the chapter entitled "Configuration"
- If desired, load the factory settings: see the chapter entitled "Configuration," menu item 9.— 1

Additional functions:

- Switching off the balance/scale: press the (ON/OFF) key
- Battery operation: automatic shut-off after 2,5 or 10 minutes; see chapter on configuration. Example: 2 minutes. If the weight readout remains unchanged and no keys are pressed for at least two minutes, the battery symbol "  " starts flashing. After another 2 seconds, the balance shuts off automatically, unless a key is pressed.

Example: Determine weight of sample

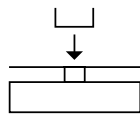
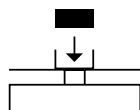
Step	Key (or instruction)	Display
1. Switch on the balance/scale Self-test runs Display: Software version	(ON/OFF)	
2. Open the in-use cover and leave open while weighing		r 3 1.0 1
3. Place container on the balance/scale (in this example, 52 g)		52.0 g
4. Zero the balance/scale	(ZERO)	0.0 g
5. Place sample in container on balance/scale (in this example, 150,2 g).		150.2 g

Description of the Keys



(ON/OFF) On/off key: switches the balance/scale on and off or switches it to the standby mode.

(ZERO) Zeros the balance; press and hold 2 seconds: opens the application menu

(CAL) Starts calibration/adjustment
(F) Starts an application program; Scrolling in application menu, configuration menu and calibration menu

(ENTER) Confirms the selected setting; Exits application, configuration & calibration menu if key is pressed and held for more than 2 seconds.

(PRINT) Generates a printout or data output

Application Programs

Toggling between Weight Units

With this application program you can toggle the display of a weight value back and forth between two weight units (see table below).

Example: Toggle weight unit from pounds [lb] (application) to grams [g] (basic unit)

Step	Key (or instruction)	Display
1. Select application program	(ZERO) > 2 sec	
2. Select Toggling between Weight Units	(F)	
3. Confirm unit	(ENTER)	
4. Select weight unit; in this example: "5. Pound" (see table below)	(F) repeatedly	
5. Confirm weight unit (pounds)	(ENTER)	
6. Place sample on balance/scale		
7. Toggle weight unit	(F)	

Menu code	Unit	Conversion factor	Display
1.uSEr*	Grams	1.00000000000	o
2.GrANS (factory setting)	Grams	1.00000000000	g
4.CARAt	Carats	5.00000000000	o
5.Pound	Pounds	0.00220462260	lb
6.ounCE	Ounces	0.03527396200	oz
7.troyo	Troy ounces	0.03215074700	ozt
8.tL.Hon	Hong Kong tael	0.02671725000	tlk
9.tL.S in	Singapore tael	0.02645544638	tl
10.tL.tA	Taiwanese tael	0.02666666000	tl
11.GRAI	Grains	15.4323583500	GN
12.PENY	Pennyweights	0.64301493100	dwt
15.tL.CH	Chinese tael	0.02645547175	tl
22.Pdo2	lb/oz	0.03527396200	lb:oz
23.nEIt	Newtons	0.00980665000	N

* User-defined conversion is customer selectable with RS-232 or USB program option.

Counting

Purpose

With the Counting program you can determine the number of parts or items.

Example: Determine the number of uncounted parts; weigh in the selectable reference sample quantity (in this example: 20)

Step	Key (or instruction)	Display
1. Select application program	(ZERO) > 2 sec	
2. Select Counting	(F) repeatedly	
3. Confirm setting Symbol "*" on the display: application is active	(ENTER)	
4. Place empty container on the balance/scale		
5. Zero the balance/scale	(ZERO)	
6. Place reference sample quantity (20) on the balance/scale		
7. Select reference sample quantity: in increments of 1 (1, 2, 3, ..., 99) or in increments of 10 (10, 20, 30, ..., 100)	(F) repeatedly (briefly) or (F) > 2 sec.	
8. Confirm selected reference sample quantity	(ENTER)	
9. Place uncounted parts on balance/scale		
10. Toggle display between mean piece weight, total weight, and quantity	(F) repeatedly	
11. Unload the balance/scale		
12. Counting application: clear the reference value	(ENTER) > 2 sec	
13. Reactivate Counting (if no other application program has been selected)	(F)	
14. Repeat procedure starting from Step 5.		

Weighing in Percent

Purpose

This application program allows you to obtain weight readouts in percent which are in proportion to a reference weight.

Example: Determine an unknown percentage; store the weight on the balance/scale as the reference percentage (100%)







Step	Key (or instruction)	Display
1. Select application program	(ZERO) > 2 sec	
2. Select Weighing in Percent	(F) repeatedly	
3. Confirm setting Symbol "*" on the display: application is active	(ENTER)	
4. Place empty container on the balance/scale		
5. Tare the balance	(ZERO)	
6. Place the reference weight for 100% on the balance/scale		
7. If desired, change the number of decimal places displayed: 100.0%, 100.00% or 100% (factory setting)	(F) repeatedly	
8. Confirm selected no. of decimal places	(ENTER)	
9. Place unknown weight on the balance/scale		
10. Toggle display between weight and percentage	(F) repeatedly	
11. Unload the balance/scale		
12. Weighing in Percent application: clear the reference percentage	(ENTER) > 2 sec	
13. Reactivate Weighing in Percent (if no other application program has been selected)	(F)	
14. Repeat procedure starting from Step 5.		

"Hold" Display

Purpose

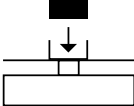
"Holds" the displayed value; also, the display will be locked for 5 seconds after removing the sample from the pan.

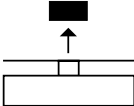
Example: Determine weight of oversized sample

Step	Key (or instruction)	Display
1. Select application program	(ZERO) > 2 sec	
2. Select Static Display	(F) repeatedly	
3. Confirm setting Symbol "*" on the display: application is active	(ENTER)	
4. If necessary: zero the balance/scale	(ZERO)	
5. Place oversized sample on balance/scale		
6. Start application program Symbol "▲" flashes on the display: the weight value is locked	(F)	
7. Unload the balance/scale: the weight value remains displayed for a further 5 seconds; or		
8. Zero the balance/scale	(ZERO)	
9. End the Display Hold application	(ENTER) > 2 sec	
10. Reactivate Display Hold (if no other application program has been selected)	(F)	
11. Repeat procedure starting from Step 5.		

Totalizing

Purpose

With this application program you can add up successive weight values exceding capacity of balance/scale.

Example: Totalizing weight values

Step	Key (or instruction)	Display
1. Select application program	(ZERO) > 2 sec	
2. Select Totalizing	(F) repeatedly	
3. Confirm setting Symbol "Σ*" on the display: application is active	(ENTER)	
4. If necessary: zero the balance/scale	(ZERO)	
5. Place sample on balance/scale (in this example, 380 g)		
6. Store value in memory. Total weight is displayed steadily; Σ symbol flashes.	(ENTER)	
7. Remove sample from balance/scale		
8. Place the next sample on the balance/scale (in this example, 575 g)		
9. Store value in memory. Totalized stored weight is displayed; symbol Σ flashes. Note: Σ symbol remains on indicating stored value in memory until cleared	(ENTER)	
10. To view the current weight for 2 seconds (if a printer is connected, a printout is generated)	(F)	
11. Clear totalizing memory (if a printer is connected, total is printed)	(F) > 2 sec	
12. End Totalizing	(ENTER) > 2 sec	
13. Reactivate Totalizing (if no other application program has been selected) (if a printer is connected, total is printed).	(F)	
14. Repeat procedure starting from Step 6.		

Specific Gravity

Purpose

Use this application program to determine the specific gravity of a sample. The result is displayed with one decimal place. Beaker and wire not included with balance/scale.

Example: Determine the specific gravity of a solid.

Step	Key (or instruction)	Display
1. Select application program	(ZERO) > 2 sec	
2. Select Specific Gravity	(F) repeatedly	
3. Confirm setting Symbol "*" on the display: application is active	(ENTER)	
4. If necessary, zero the balance/scale	(ZERO)	
5. Start application program	(F)	
6. Confirm the display, "AIR-UAL"	(ENTER)	
7. Determine weight of the sample in air: place sample on the balance/scale		
8. Store weight-in-air value	(ENTER)	
9. Remove sample from balance/scale		
10. Determine weight of sample in liquid: connect wire and set up beaker		
11. Confirm the display "114.4 g"	(ENTER)	
12. Place sample in liquid		
13. Store the weight-in-liquid value and view the result	(ENTER)	
14. Clear the display	(ZERO)	
15. Exit the Specific Gravity application	(ENTER) > 2 sec	
16. Reactivate Specific Gravity (if no other application program has been selected)	(F)	
17. Repeat procedure starting from Step 5.		

Calibration/Span Adjustment











Calibration is recommended after initial installation and each time the balance/scale is moved.

Features

- Calibration/adjustment can be performed only when:
 - there is no load on the balance/scale,
 - the balance/scale is zeroed, and
 - the internal signal is stable.
- If these conditions are not met, an error message is displayed.

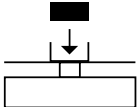

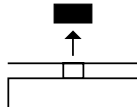
The weight required for calibration/adjustment is displayed. Standard calibration weights for selected models: to remove, see instructions on page 4. Press (F) to select a different weight value. To cancel the procedure: press and hold the (ENTER) key (> 2 sec.).

Example: Calibrate/adjust span of the balance/scale (here: model VIC-5101)

Step	Key (or instruction)	Display
1. Switch on the balance/scale	(ON/OFF)	
2. Zero the balance/scale	(ZERO)	
3. Start calibration The preset calibration weight is displayed without the weight unit (in this example, 5000 g)	(CAL)	
4. To select a different calibration weight value	(F) repeatedly	 
5. Confirm calibration weight value and start calibration/span adjustment	(ENTER)	
After the zero point is stored, the required calibration weight flashes on the display.		
6. Place the required calibration weight on the balance/scale		
The readout stops flashing if the weight is applied within the defined time limit and tolerance. If the weight value is accepted, the display stops flashing and the stability symbol  appears on the display.		
7. Remove the calibration weight		
8. Calibration has been completed		

Configuration (Setup Menu)

To configure the balance/scale; i.e., adapt the balance/scale to individual requirements.

Step	Key (or instruction)	Display
1. Switch off the balance/scale	(ON/OFF)	
2. Switch on the balance/scale and while all segments are displayed	(ON/OFF) (ZERO) briefly	 

Navigation in the Setup Menu

Key	Press briefly	Press and hold
(ENTER)	Menu level: move to the right (cyclical)	Confirm setting
(F)	Menu item: Scrolling	—
(ZERO)	Menu level: Move to the left	Save settings and exit Setup

Parameter Settings (Overview)

			○ Factory setting	✓ User-defined setting
Setup menu	1 Weighing	1.1. Adapt filter	1.1.1	Very stable conditions
			1.1.2	○ Stable conditions
			1.1.3	Unstable conditions
			1.1.4	Very unstable conditions
		1.2. Application filter	1.2.1	○ Final readout
			1.2.2	Filling
		1.3. Stability range	1.3.1	1.3.1
	1.3.2			1/2 digit
	1.3.3			1 digit
	1.3.4		○ 2 digits	
	1.3.5		4 digits	
	1.5. Calib./adjust./linearization: Function of the (CAL) key	1.5.1	○ Calibration/adjustment	
		1.5.2	Linearization: for service personnel only	
		1.5.3	Key blocked	
	1.6. Auto zero	1.6.1	○ On	
1.6.2		Off		
1.7. 1st weight unit, or 2nd unit in Toggle Weight Units app.	1.7.1	User-defined unit; see		
	to 1.7.23	"Toggling between Weight Units"		
5. and 6.	Only relevant with built-in data interface: see corresponding interface description			
8. Additional functions	8.1. Block key functions	8.1.1	All keys blocked except for (ON/OFF) and (ZERO)	
		8.1.2	○ All keys unblocked	
	8.2. Automatic shut-off	8.2.1	○ After 2 minutes	
		8.2.2	After 5 minutes	
8.2.3		After 10 minutes		
9. Reset menu	9.1. Factory settings	9.1.1	Restore	
		9.1.2	○ Do not restore	

Error Codes

Error codes are shown on the main display for approx. 2 seconds. The program then returns automatically to the previous mode.

Display/Problem	Cause	Solution
No segments appear on the display	No power available	Check the power supply
	The AC adapter is not plugged in	Plug in the AC adapter
	Battery is drained	Replace battery; recharge battery using external charger
<i>oL</i>	The load exceeds the balance/scale capacity	Unload the balance/scale
<i>uL</i>	Weighing pan not in place	Place the weighing pan on the balance/scale
	Something is touching the weighing pan	Move the object that is touching the weighing pan
<i>dISErr</i>	Display overflow: Value cannot be shown on the display	Reduce load on the balance/scale
<i>CALErr</i>	Calibration parameter not met; e.g.: – Balance/scale not zeroed – Balance/scale is loaded	Calibrate only when zero is displayed Press (ZERO) to tare the balance/scale Unload the balance/scale
<i>APPErr</i>	Weight is too light or there is no sample on the balance/scale with application in use	Increase the weight on the balance/scale
<i>PrtErr</i>	Data interface for printing is blocked	Contact the Acculab customer service center
Max. weighing capacity is less than indicated under "Specifications"	The balance/scale was switched on without the weighing pan in place	Place the weighing pan on the balance/scale and press (ON/OFF)
The weight readout is obviously wrong	The balance/scale was not calibrated/adjusted before weighing	Calibrate/adjust the balance/scale
	Balance/scale not zeroed	Zero the balance/scale

If any other errors occur, contact your local Acculab customer service center.

Overview

Specifications

Model		VIC-303	VIC-123	VIC-4MG	VIC-2MG	VIC-612	VIC-412	VIC-212
Weighing capacity	g	300	120	410	210	610	410	210
Readability	g	0.001	0.001	0.005	0.005	0.01	0.01	0.01
Tare range (subtractive)	g	300	120	410	210	610	410	210
Linearity	≤±g	0.004	0.003	0.01	0.01	0.03	0.03	0.035
Operating temperature range		10°C to 30°C (273°K to 303°K; 50°F to 86°F)						
Stabilization time (average)	s	2.5	2.5	2.5	2.5	2	2	2
Adaptation to ambient conditions		By selection of 1 of 4 optimized filter levels; display update: 0.1–0.8 (depends on filter level selected)						
Calibration weight	g	200 (F1)	100 (F1)	200 (F1)	200 (F2)	200 (F2)	200 (F2)	200 (M1)
Net weight, approx.	kg	1.3	1.2	1.3	1.3	1.35	1.35	1.2
Pan size	mm	97 Ø	97 Ø	97 Ø	97 Ø	142x130	142x130	97 Ø
Power source/voltage/frequency		AC adapter, 230 V or 115 V, +15% to – 20%, 48–60 Hz						
Power consumption (average)	W	1	1	1	1	0.75	0.75	0.75
Hours of operation w/ 9V battery:								
– Alkaline (approx.)	h	–	–	–	–	11	11	14
– Rechargeable, fully ch., (NiMH), avg.	h	–	–	–	–	2.5	2.5	4

Model		VIC-5101	VIC-3101	VIC-1501	VIC-711	VIC-511	VIC-10KG	VIC-6KG	VIC-4KG
Weighing capacity	g	5100	3100	1500	710	510	10100	6100	4100
Readability	g	0.1	0.1	0.1	0.1	0.1	1	1	1
Tare range (subtractive)	g	5100	3100	1500	710	510	10100	6100	4100
Linearity	≤±g	0.2	0.2	0.2	0.2	0.2	2	2	1
Operating temperature range		10°C to 30°C (273°K to 303°K; 50°F to 86°F)							
Stabilization time (average)	s	2	2	1.5	1.5	1.5	1.5	1.5	1.5
Adaptation to ambient conditions		By selection of 1 of 4 optimized filter levels; display update: 0.1–0.8 (depends on filter level selected)							
Calibration weight	kg	5 (F2)	2 (F2)	1 (M1)	0,2 (M2)	0,2 (M2)	5 (M1)	5 (M2)	2 (M2)
Net weight, approx.	kg	1.1	1.1	1.1	1.25	1.25	1.1	1.1	1.1
Pan size	mm	142x130							
Power source/voltage/frequency		AC adapter, 230 V or 115 V, +15% to – 20%, 48–60 Hz							
Power consumption (average)	W	1	1	0.75	0.75	0.75	0.75	0.75	0.75
Hours of operation w/ 9V battery:									
– Alkaline (approx.)	h	11	11	14	14	14	14	14	14
– Rechargeable, fully ch., (NiMH), avg.	h	2.5	2.5	4	4	4	4	4	4

Accessories (Options)

Product	Order No.
Data interface , mounting kit	
– RS-232 interface with cable	YADAP-RS
– USB interface with cable	YADAP-USB
Data printer	YDP03-OCE
Lock-down capability (for anti-theft locking device)	LC-1
Calibration weights	
– for VIC-5101 (5 kg; F2)	YCW6548-00
– for VIC-3101 (2 kg; F2)	YCW6248-00
– for VIC-1501 (1 kg; M1)	YCW615-00
– for VIC-10KG (5 kg; M1)	YCW655-00
– for VIC-6KG (5 kg; M2)	YCW656-00
– for VIC-4KG (2 kg; M2)	YCW626-00
– for weight compartment, (right side), (100 g;F1)	Available on request

Product	Order No.
In-use cover:	
– for models without glass draft shield	Available on request
– for models with glass draft shield	Available on request
Round glass draft shield (25 mm high)	Available on request
Weighing pan:	
– Round	Available on request
– Rectangular	Available on request
Pan support:	
– Round	Available on request
– Rectangular	Available on request
Leveling feet (set of one adjustable foot and one fixed foot)	Available on request
Plug for level indicator port	Available on request
Covers:	
– Battery compartment	Available on request
– Interface port	Available on request
– Below-balance/scale port	Available on request
Weight compartment	Available on request

CE Marking

The balance/scale complies with the following EC Directives and European Standards:

Council Directive 89/336/EEC “Electromagnetic compatibility (EMC)”

Applicable European Standards:

Limitation of emissions:

In accordance with product standard EN 61326-1 Class B (residential area)

Defined immunity to interference:

in accordance with product standard EN 61326-1

(minimum test requirements, non-continuous operation)

Important Note:

The operator shall be responsible for any modifications to Acculab equipment and must check and, if necessary, correct these modifications.

On request, Acculab will provide information on the minimum operating specifications (in accordance with the Standards listed above for defined immunity to interference).

73/22/EEC “Electrical equipment designed for use within certain voltage limits”

Applicable European Standards:

EN 60950

Safety of information technology equipment including electrical business equipment

EN 61010

Safety requirements for electrical equipment for measurement, control and laboratory use

Part 1: General requirements

If you use electrical equipment in installations and under ambient conditions requiring higher safety standards, you must comply with the provisions as specified in the applicable regulations for installation in your country.